

इंटरनेट

मानक

Disclosure to Promote the Right To Information

Whereas the Parliament of India has set out to provide a practical regime of right to information for citizens to secure access to information under the control of public authorities, in order to promote transparency and accountability in the working of every public authority, and whereas the attached publication of the Bureau of Indian Standards is of particular interest to the public, particularly disadvantaged communities and those engaged in the pursuit of education and knowledge, the attached public safety standard is made available to promote the timely dissemination of this information in an accurate manner to the public.

“जानने का अधिकार, जीने का अधिकार”

Mazdoor Kisan Shakti Sangathan

“The Right to Information, The Right to Live”

“पुराने को छोड़ नये के तरफ”

Jawaharlal Nehru

“Step Out From the Old to the New”

IS 6306 (1971): Methods of test for reclaimed rubber [PCD
13: Rubber and Rubber Products]



“ज्ञान से एक नये भारत का निर्माण”

Satyanarayan Gangaram Pitroda

“Invent a New India Using Knowledge”



“ज्ञान एक ऐसा खजाना है जो कभी चुराया नहीं जा सकता है”

Bhartrhari—Nitiśatakam

“Knowledge is such a treasure which cannot be stolen”

BLANK PAGE



IS : 6306 - 1971
(Reaffirmed 2002)

Indian Standard
**METHODS OF TEST
FOR RECLAIMED RUBBER**

(Third Reprint AUGUST 2004)

UDC 678.46.001.4

© *Copyright* 1972

**BUREAU OF INDIAN STANDARDS
MANAK BHAVAN, 9 BAHADUR SHAH ZAFAR MARG
NEW DELHI 110002**

Gr 6

April 1972

AMENDMENT NO. 2 MARCH 1986
TO
IS:6306-1971 METHODS OF TEST FOR RECLAIMED RUBBER

(Page 22, clause 4.2, line 2) - Substitute
'(relative density - approximately 1.5)' for '(relative
density 1.5)'.
(PCDC 14)

AMENDMENT NO. 1 APRIL 1975
TO
IS : 6306 - 1971 METHODS OF TEST FOR
RECLAIMED RUBBER

Addendum

[*Page 13, RR : 5*) — Add the following alternative method for the determination of carbon black after 6.1 :

DETERMINATION OF CARBON BLACK
(ALTERNATIVE METHOD)

1. SCOPE

1.1 This method is intended for determination of carbon black in reclaimed rubber.

2. OUTLINE OF THE METHOD

2.1 The reclaimed rubber is heated in a furnace at about 1 000°C in an atmosphere of nitrogen to distill all other materials except ash and free carbon. Ash is also determined separately and from the difference of the two, amount of carbon black is obtained.

3. APPARATUS

3.1 Electrical Combustion Furnace — tubular in shape, about 325 mm in length and having a heating zone of about 275 mm, and capable of maintaining a temperature of $1\ 000 \pm 25^\circ\text{C}$.

3.2 Combustion Tube — of transparent silica, about 725 mm in length, 26 and 28 mm in inner and outer diameter respectively.

3.3 Nitrogen Gas Cylinder

3.4 Gas Washing Bottles

3.5 Glazed Porcelain Boat

4. PROCEDURE

4.1 Ignite the boat and weigh it after cooling. Accurately weigh, in the boat, about 1 g of the homogenized sample prepared as in 3.1.1 (*see page 4*). Heat the furnace with the combustion tube to approximately 1 000°C. Draw out the combustion tube a little bit from the hot zone and clean it with nitrogen gas for 1 minute to drive away the air. Introduce the weighed boat with sample into the combustion tube, connect the gas flow and push the tube so that the boat is in the hot zone of the furnace. At first dense,

black-brown smoke will come out of the combustion tube which will slowly turn to white smoke. When white smoke becomes thinner, draw out the combustion tube from the furnace. Continue the flow of nitrogen for 2-3 minutes more. Cut off the supply of nitrogen and take out the boat carefully avoiding spilling and keep it in a desiccator till it is cooled. Weigh the boat with the ignited sample.

NOTE — Nitrogen gas used shall be cleaned by passing it through washing bottles containing glycerine and alkaline pyrogallol (20 – 30 g of pyrogallol in 10 ml of about 30 percent potassium hydroxide) respectively to remove the moisture and traces of oxygen present in nitrogen.

5. CALCULATION

5.1 Calculate the carbon black content as follows:

5.1.1 Total fillers,
percent by mass (A) = $\frac{M_3 - M_1}{M_2 - M_1} \times 100$

where

M_3 = mass in g of the boat with the sample after ignition,

M_1 = mass in g of empty boat, and

M_2 = mass in g of the boat with sample.

5.1.2 Ash content, percent by mass (calculated as given in RR : 3) = B.

5.1.3 Carbon black, percent by mass = A – B.

(CDC 42)

Printed at Dee Kay Printers, New Delhi

Indian Standard

METHODS OF TEST FOR RECLAIMED RUBBER

Rubber Sectional Committee, CDC 42

<i>Chairman</i>	<i>Representing</i>
SHRI LALIT MOHAN JAMNADAS	The Cosmos India Rubber Works Pvt Ltd, Bombay
<i>Vice-Chairman</i>	
SHRI P. P. MUKHERJEE	Bata Shoe Co Pvt Ltd, Calcutta
<i>Members</i>	
SHRI S. C. NANDY (<i>Alternate to</i> Shri P. P. Mukherjee)	Rubber Research Institute of India, Kottayam
SHRI V. K. BHASKARAN NAIR	Indian Rubber Manufacturers' Research Association, Bombay
SHRI K. C. ANANTH (<i>Alternate</i>)	The Arakkunnam Co-operative Rubber Marketing Society Ltd, Arakkunnam (Kerala)
DR M. L. BHAUMIK	Ministry of Defence (DGI)
SHRI J. C. CHALY	National Test House, Calcutta
SHRI B. H. DALAL	Ministry of Defence (R & D)
SHRI M. KUMARAN (<i>Alternate</i>)	Peirce Leslie & Co Ltd, Coimbatore
DR D. K. DAS	Indian Rubber Industries Association, Bombay
SHRI A. GHOSH (<i>Alternate</i>)	The Association of Rubber Manufacturers in India, Calcutta
SHRI S. L. GANDHI	The Rubber Board, Kottayam
SHRI M. G. BHARGAVA (<i>Alternate</i>)	The Plantation Corporation of Kerala Ltd, Kottayam
SHRI P. K. MADHAVA MENON	Synthetics & Chemicals Ltd, Bombay
DR K. N. MODAK	Association of Planters of Kerala, Kottayam
SHRI B. B. SANGTANI (<i>Alternate</i>)	Madras Rubber Factory, Madras
SHRI S. MUKHERJEE	National Chemical Laboratory (CSIR), Poona
SHRI L. N. SATHIA (<i>Alternate</i>)	Directorate General of Technical Development, New Delhi
SHRI P. MUKUNLA MENON	Padinjarekara Agencies (Pvt) Ltd, Kottayam
SHRI K. K. NAIR	
SHRI K. A. PAUL (<i>Alternate</i>)	
SHRI M. M. PATEL	
SHRI V. C. NANAVATI (<i>Alternate</i>)	
SHRI R. H. PAYLOR	
SHRI K. M. PHILIP	
SHRI D. RAGHUNATH	
DR N. V. C. RAO	
SHRI K. C. SEKAR	

(Continued on page 2)

IS : 6306 - 1971

(*Continued from page 1*)

<i>Members</i>	<i>Representing</i>
SHRI S. SUBRAMANIAN SHRI A. L. N. RAMANATHAN CHETTIAR (<i>Alternate</i>)	Kanyakumari Distt Planters' Association, Nagercoil
SHRI K. C. THOMAS SHRI T. D. MATHEW (<i>Alternate</i>)	The Rubber Dealers' Association, Kottayam
SHRI M. M. VARGHESE SHRI M. M. MUTHIAH (<i>Alternate</i>)	United Planters' Association of Southern India, Coonoor
SHRI D. DAS GUPTA, Director (Chem)	Director General, ISI (<i>Ex-officio Member</i>)

Secretary

SHRI SATISH CHANDER
Deputy Director (Chem), ISI

Methods of Testing Subcommittee, CDC 42 : 1

Members

SHRI V. K. BHASKARAN NAIR SHRI K. C. ANANTH (<i>Alternate</i>)	The Rubber Board, Kottayam
DR S. N. CHAKRAVARTY SHRI R. R. PANDIT (<i>Alternate</i>)	Bayer (India) Ltd, Bombay
DR D. K. DAS SHRI A. GHOSH (<i>Alternate</i>)	National Test House, Calcutta
SHRI W. G. DESAI DR A. S. GHAG SHRI P. D. KHEMKA SHRI PULIN L. KINARIWALA (<i>Alternate</i>)	Indian Rubber Regenerating Co Ltd, Thana Monsanto Chemicals of India Pvt Ltd, Bombay The Cosmos India Rubber Works Pvt Ltd, Bombay
SHRI P. K. MADHAVA MENON SHRI N. S. NAGARAJA RAO SHRI MURARI KARMAKAR (<i>Alternate</i>)	Peirce Leslie & Co Ltd, Coimbatore L. G. Balakrishnan & Bros Pvt Ltd, Coimbatore
SHRI M. M. PATEL SHRI P. P. MAHALINGAM (<i>Alternate</i>)	Synthetics & Chemicals Ltd, Bombay
SHRI L. N. SATHIA SHRI I. DANIEL (<i>Alternate</i>)	Dunlop India Ltd, Calcutta
SHRI K. C. SEKAR	Pandinjarekara Agencies (Pvt) Ltd, Kottayam

Indian Standard

METHODS OF TEST FOR RECLAIMED RUBBER

0. FOREWORD

0.1 This Indian Standard was adopted by the Indian Standards Institution on 29 October 1971, after the draft finalized by the Rubber Sectional Committee had been approved by the Chemical Division Council.

0.2 Reclaimed rubber is extensively used in the manufacture of many rubber goods apart from some compounds for tyres. This is used either alone or in combination of natural and SBR type of synthetic rubbers. The usage of reclaimed rubber manufactured from NR and SBR or blend of NR/SBR has increased to a considerable extent in the rubber industry and, therefore, it is necessary to have standard methods for testing these products.

0.3 This standard covers methods for all tests normally carried out for the reclaimed rubber manufactured from the scrap of natural or styrene-butadiene rubber (SBR) or blend of these.

0.4 In reporting the result of a test or analysis made in accordance with this standard, if the final value, observed or calculated, is to be rounded off, it shall be done in accordance with IS : 2-1960*.

1. SCOPE

1.1 This standard prescribes the methods of test for reclaimed rubber. It covers test procedures for determining volatile matter (RR : 1); relative density (RR : 2); ash (RR : 3); solvent extract (RR : 4); carbon black (RR : 5); rubber hydrocarbon (RR : 6); Mooney viscosity (RR : 7); and procedure for compounding (RR : 8).

2. QUALITY OF REAGENTS

2.1 Unless specified otherwise, pure chemicals and distilled water (see IS : 1070-1960†) shall be employed in tests.

NOTE — 'Pure chemicals' shall mean chemicals that do not contain impurities which affect the results of analysis.

*Rules for rounding off numerical values (*revised*).

†Specification for water, distilled quality (*revised*).

3. PREPARATION OF TEST SAMPLES

3.1 Draw a representative sample in accordance with the details prescribed in IS : 5599-1970*. A packet weighing 50 kg shall be considered as a bale. The scale of sampling shall be in accordance with Table 1A of IS : 5599-1970*.

3.1.1 *Preparation of Test Portion* — Weigh the test piece accurately to the nearest 0.1 g and then pass through the nip of a roll mill where the nip is adjusted to 2.5 mm and rolls are maintained at standard temperature for testing (see IS : 196-1966†). Carry out the homogenization of rubber by passing the rubber through the nip 10 times. Roll the rubber blanket between each passage and insert end-wise. Put back all the solid matter that falls out from the rubber again, mill and reweigh rubber to the nearest 0.1 mg, pack and label properly for tests.

NOTE — If it is not possible to proceed immediately with the determination of volatile matter, the test portion for this determination shall be placed in an air-tight container so as to conserve the volatile matter.

*Methods for sampling of raw rubber.

†Atmospheric conditions for testing (*revised*).

DETERMINATION OF VOLATILE MATTER

(RR : 1)

1. SCOPE

1.1 This method is intended for the determination of percentage of the constituents of the reclaimed rubber, which are volatile at 105°C.

2. APPARATUS**2.1 Chemical Balance****2.2 Desiccator with Efficient Desiccant**

2.3 Oven — capable of maintaining $105 \pm 2^\circ\text{C}$.

2.4 Silica or Porcelain Dishes**3. PROCEDURE**

3.1 Cut approximately 10 g of reclaimed rubber from the prepared homogeneous test portion (*see* 3.1.1, Page 4), into pieces smaller than 2 mm and immediately weigh to an accuracy of 1 mg in a tared dish. If it is not possible to weigh these two portions immediately, keep them in an air-tight container wrapped in polyethylene sheet so as to conserve their volatile matter. Keep the dish with the sample in an air-oven at $105 \pm 2^\circ\text{C}$ for 2 hours. Remove the dish, cover and cool in a desiccator and weigh. Repeat heating and weighing until the loss on successive weighings at half hour intervals is less than 1 mg.

4. CALCULATION

4.1 Calculate the volatile matter from the formula:

$$\text{Volatile matter, percent by weight} = \frac{A-B}{A} \times 100$$

where

A = weight in g of the homogenized test portion, and

B = final weight of the test portion after drying.

**DETERMINATION OF RELATIVE DENSITY
(RR : 2)**

1. SCOPE

1.1 This method is intended for the determination of relative density of reclaimed rubber.

2. OUTLINE OF THE METHOD

2.1 Relative density of reclaimed rubber is determined by the hydrostatic method with or without the help of a sinker, and the results are expressed as density in g/ml. The density of the material shall be taken to be numerically equal to its relative density.

3. APPARATUS

3.1 Balance — weighing to 1 mg.

3.2 Balance Straddle — a pan straddle of convenient size to support the beaker and permit determination of the weight of the test piece in water.

3.3 Beaker — 250 ml capacity (or smaller if necessitated by the design of the balance).

3.4 Copper Wire — approximately 0.1 mm in diameter.

3.5 Sinker — for test pieces with relative density less than 1.

4. TEST METHODS

4.1 Preparation of the Test Piece — The test piece shall be approximately 40 × 40 mm and 1.5 mm thick and shall have a surface, free from crevices as far as possible to get a suitable weight of 3 to 5 g. The test pieces shall be pressed for 10 minutes at 75°C under a minimum pressure of 30 kg/cm² to remove the entrapped air bubbles.

4.2 Conditioning of Test Piece — The test piece as prepared in 4.1 shall be conditioned at 27 ± 2°C for at least 12 hours.

4.3 Procedure — Suspend the test piece from the hook on one side of the balance using a suitable length of wire, so that the bottom of the test piece does not touch the bottom of the beaker. Counterbalance the wire previously by a length of wire on the other pan. Repeat the weighing with the test piece (and sinker when the relative density of the test piece is less than 1) completely immersed in the freshly boiled and cooled distilled water to a temperature of 27 ± 2°C, in a beaker. Allow sufficient time for the test piece to attain the temperature of the water. Remove the air bubbles and determine the weight to the nearest mg.

NOTE 1 — If the relative density of the test piece is less than 1, a sinker is necessary. In that case the sinker alone shall also be weighed in water.

NOTE 2 — The main sources of error are: (a) air bubbles adhering to the outer surfaces of the test piece during weighings in water; (b) surface tension effects on the wire; and (c) convection currents in the water in which the test piece is suspended. To minimize these, the temperature of the water and of the air in the balance case should be the same. To minimize the adherence of bubbles to the pieces of rubber or the walls of the bottle, it is permissible either to dip the rubber test piece prior to testing momentarily into a suitable solvent such as ethyl alcohol or methyl alcohol, miscible with water and having a negligible swelling or leaching action on rubber, or to add trace of detergent to distilled water.

5. CALCULATION

5.1 Calculate the relative density of reclaimed rubber as follows:

a) Relative density of reclaimed rubber
(when sinker is not used)
$$= \frac{W}{W_1 - W_2}$$

where

W_1 = weight in g of the test piece in air, and

W_2 = weight in g of the test piece in water.

b) Relative density of rubber
(when sinker is used)
$$= \frac{W_1}{W_1 \pm W_2 - W_3}$$

where

W_1 = weight in g of the test piece in air,

W_2 = weight in g of the sinker in water, and

W_3 = weight in g of the rubber and sinker in water.

6. REPORT

6.1 The report shall state the average of at least two relative density determinations and the temperature at which the test was carried out.

DETERMINATION OF ASH
(RR : 3)

1. SCOPE

1.1 This method is intended for the determination of ash in reclaimed rubber.

2. APPARATUS

2.1 Chemical Balance

2.2 Silica or Porcelain Crucible

2.3 Desiccator with Efficient Desiccant

2.4 Muffle Furnace — with pyrometer and thermostatic control.

3. PROCEDURE

3.1 Clean a crucible thoroughly, ignite, cool and weigh. Weigh about 1 to 2 g of the prepared test portion (see 3.1.1, Page 4) of reclaimed rubber to the nearest 1 mg into the crucible. Heat the crucible over a small flame in the beginning. Take care not to ignite the reclaimed rubber rapidly to avoid spurting. Transfer the crucible to a muffle furnace when the reclaimed rubber is completely decomposed to a charred mass. Heat in the muffle furnace at a temperature between 500°C and 550°C for one hour. Allow the crucible to cool in a desiccator. Weigh to the nearest mg. Repeat heating, cooling and weighing until the change in weight between successive weighings is not more than 1 mg.

4. CALCULATION

4.1 Calculate ash content as follows:

$$\text{Ash content, percent by mass} = \frac{W_3 - W_2}{W_1} \times 100$$

where

W_3 = weight in g of the crucible plus ash,

W_2 = weight in g of the crucible, and

W_1 = weight in g of the rubber samples.

DETERMINATION OF SOLVENT EXTRACT

(RR : 4)

1. SCOPE

1.1 This method is intended for the determination of materials, soluble in acetone, present in the reclaimed rubber.

2. OUTLINE OF THE METHOD

2.1 A weighed test portion is extracted in an all-glass extraction apparatus for 12 to 16 hours. When extraction is complete the solvent is evaporated and the solvent extract is calculated finally from the weight of the matter extracted.

3. APPARATUS

3.1 **Extraction Apparatus** — The extraction apparatus is of the reflux type with the condenser placed immediately above the cup which holds the rubber. The cup is situated in the vapour of the boiling solvent and is emptied by a siphon. The apparatus is of glass except in patterns where an extraction cup is suspended from the end of the condenser, in which case platinum wire is used for the suspension. The apparatus fits together without the use of cork, rubber or metal and in such a manner that loss of vapour during extraction does not exceed 20 percent of the extracting liquid.

3.1.1 Two types of apparatus are shown in Fig. 1.

3.2 **Filter Paper** — acid-washed, hardened.

3.3 **Nylon Cloth** — open weave, continuous filaments.

4. REAGENT

4.1 **Acetone** — conforming to IS : 170-1966*.

5. PROCEDURE

5.1 Weigh out about 1 g of the rubber sheet to the nearest mg from the homogenized piece of 1.6 mm thickness as prepared in 3.1.1 (see Page 4) and wrap in a filter paper which has been previously extracted with acetone in such a manner that the pieces are separated from each other by the filter paper layer. Alternatively, cut the sample into small pieces of a size not more than 1.5 mm thickness at any place. Place the test portion in the extraction apparatus and pour in sufficient acetone to fill the

*Specification for acetone (first revision).

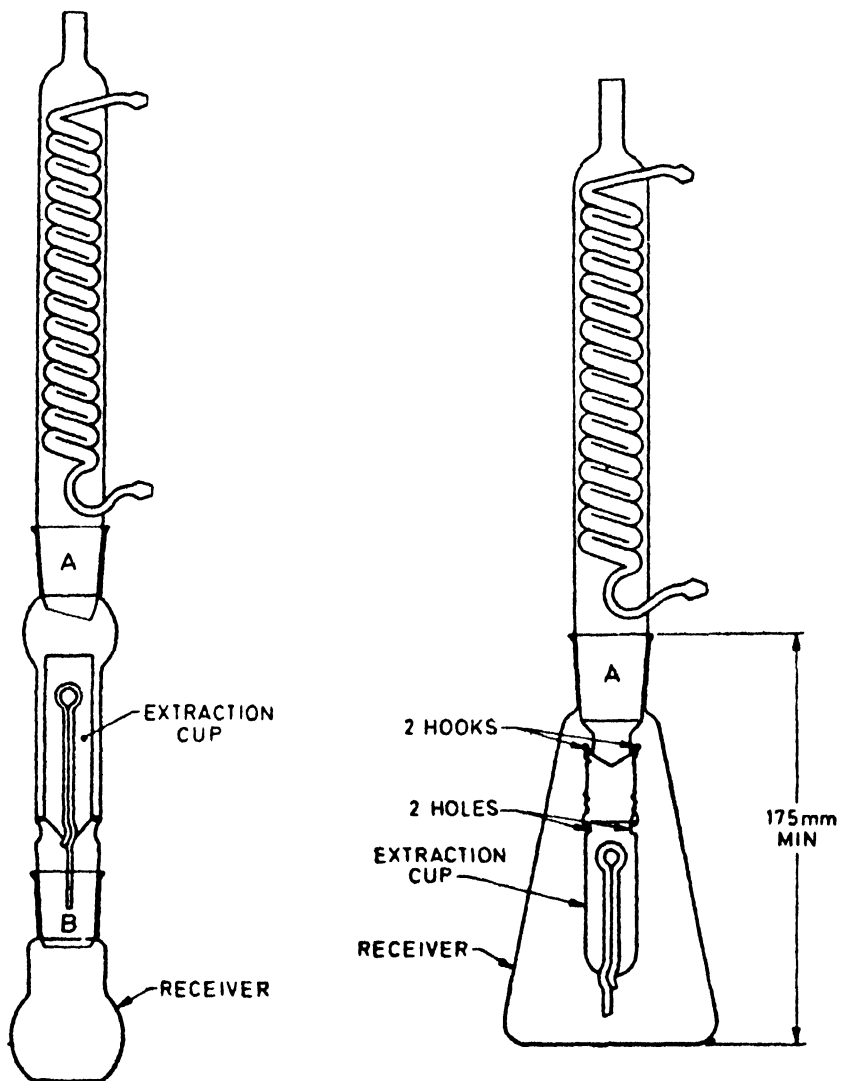

TYPE I

A - JOINT* 34/35
TYPE 2

EXTRACTION CUP	JOINTS*		RECEIVER
	A	B	
ml			ml
20 - 30	34/35	34/35	150
50 - 60	45/50	34/35	250

FIG. 1 EXTRACTION APPARATUS

extraction cup two or three times. Assemble the apparatus as shown in the figure and heat the extraction vessel continuously on a thermostatically controlled water-bath for not less than 12 hours and not more than 16 hours, the rate of evaporation being controlled to give 6 to 8 extractions per hour. After the extraction period is over, recover the combined acetone from the extraction flask and cup by distillation. After most of the acetone is recovered, dry the contents of the flask in an oven at 70 to 73°C for about 1 hour to remove the last traces of acetone. Cool the flask in a desiccator to room temperature and weigh again. Repeat heating, cooling and weighing until the change in weight between successive weighings is less than 2 mg.

6. CALCULATION

6.1 Calculate the weight of the extract as a percentage of the test portion as follows:

$$\begin{array}{l} \text{Solvent extract, percent} \\ \text{by weight} \end{array} = \frac{W_1}{W_2} \times 100$$

where

W_1 = weight in g of the matter extracted, and

W_2 = weight in g of the test portion.

DETERMINATION OF CARBON BLACK

(RR : 5)

1. SCOPE

1.1 This method is intended for the determination of carbon black in reclaimed rubber.

2. OUTLINE OF THE METHOD

2.1 The reclaimed rubber is heated with concentrated nitric acid to oxidize all organic matter and to leave free carbon. The free carbon is then separated by filtration for estimation.

3. APPARATUS

3.1 Desiccator

3.2 Gooch Crucible — with asbestos pad.

3.3 Muffle Furnace — capable of maintaining a temperature of $900 \pm 25^\circ\text{C}$.

4. REAGENT

4.1 Concentrated Nitric Acid — conforming to IS : 264-1968*.

5. PROCEDURE

5.1 Accurately weigh about 0.5 g of the homogenized sample prepared as in 3.1.1 (*see* Page 4). Extract the sample with acetone and, after drying at 100°C , transfer it to a beaker and add 30 ml of concentrated nitric acid to it. Cover the beaker with a watch glass and heat on a water-bath carefully for about 1 hour, till the reaction is subsided completely and carbon black has settled down. Cool and filter through a 'prepared' Gooch crucible with asbestos pad carefully to transfer all carbon black to the crucible. When all carbon black has been transferred, wash it with warm concentrated nitric acid and then with hot water till the filtrate is free from acid. At this stage replace the filter flask containing the acid and washings by another flask to avoid contamination of nitric acid with subsequent washing of acetone which may cause explosion. Wash with warm acetone the contents of the crucible, taking care not to disturb the pad. After washing with about 30 to 40 ml of acetone, dry the crucible in an oven at $100 \pm 5^\circ\text{C}$ for about 1 hour. Cool in a desiccator and weigh. Place the crucible in a muffle furnace at about $900 \pm 25^\circ\text{C}$ for about 1 hour to burn off all carbon black. Cool to room temperature and weigh again.

*Specification for nitric acid (*first revision*).

6. CALCULATION

6.1 Calculate carbon black content as follows:

$$\begin{array}{l} \text{Carbon black, percent} \\ \text{by mass} \end{array} = \frac{B-C}{A} \times 100$$

where

B = weight in g of the sample after extraction with acetone and drying,

C = weight in g of the sample after burning off carbon black, and

A = weight in g of the sample taken.

**DETERMINATION OF RUBBER HYDROCARBON
(RR : 6)**

1. SCOPE

1.1 This method is intended for the determination of rubber hydrocarbon present in reclaimed rubber.

2. OUTLINE OF THE METHOD

2.1 The ash, solvent extract, volatile matter and carbon black contents are first determined. Rubber hydrocarbon is then calculated by subtracting the sum of the percentage values of ash, volatile matter, carbon black and solvent extract from 100.

3. PROCEDURE

3.1 Determine volatile matter according to RR : 1.

3.2 Determine ash according to RR : 3.

3.3 Determine solvent extract according to RR : 4.

3.4 Determine carbon black content according to RR : 5.

4. CALCULATION

4.1 Calculate rubber hydrocarbon as follows:

$$\begin{array}{l} \text{Rubber hydrocarbon content (RHC),} \\ \text{percent by mass} \end{array} = 100 - x$$

where

x = sum of all the percentage values obtained in **3.1** to **3.4**.

MOONEY VISCOSITY

(RR : 7)

1. SCOPE

1.1 This method covers a test procedure for the determination of Mooney viscosity of reclaimed rubber with the help of shearing disk viscometer.

2. OUTLINE OF THE METHOD

2.1 The test involves the application of a torque to a metal disk in a cylindrical chamber filled with rubber under specified conditions. A number proportional to the torque necessary to rotate the disk is taken as an index of the viscosity of the rubber.

3. APPARATUS

3.1 The essential parts of the apparatus are a rotor, a hollow cylindrical die, a means for rotating the rotor, a means for indicating the torque required to rotate the rotor, and controls for maintaining the die at a constant temperature (*see* Fig. 1). The rotor and die cavity have the following dimensions:

Rotor diameter	38.10 ± 0.03 mm
Rotor thickness	5.55 ± 0.03 mm
Die cavity diameter	50.90 ± 0.15 mm
Die cavity depth	10.60 ± 0.03 mm

3.1.1 The die cavity (*see* Fig. 2) should preferably be formed from only two pieces of unplated hardened steel for improved heat transfer and have radial V-grooves on the flat surfaces to retard slipping. The grooves are spaced at 20° intervals, and extend from at least the 7 mm circle to the 47 mm circle; each groove forms a 90° angle in the die surface with the bisector of the angle perpendicular to the surface and is 1.00 ± 0.25 mm wide at the surface.

3.1.2 The die cavity (*see* Fig. 3) should alternatively be formed from four pieces of steel with rectangular-section grooves (*see* Fig. 3A and 3B) on the cavity surfaces to retard slipping. The grooves are 0.80 ± 0.02 mm wide of uniform depth between 0.30 ± 0.05 mm, and spaced on 1.60 ± 0.04 mm centres. The flat surfaces of the cavity have two sets of these grooves at right angles to each other.

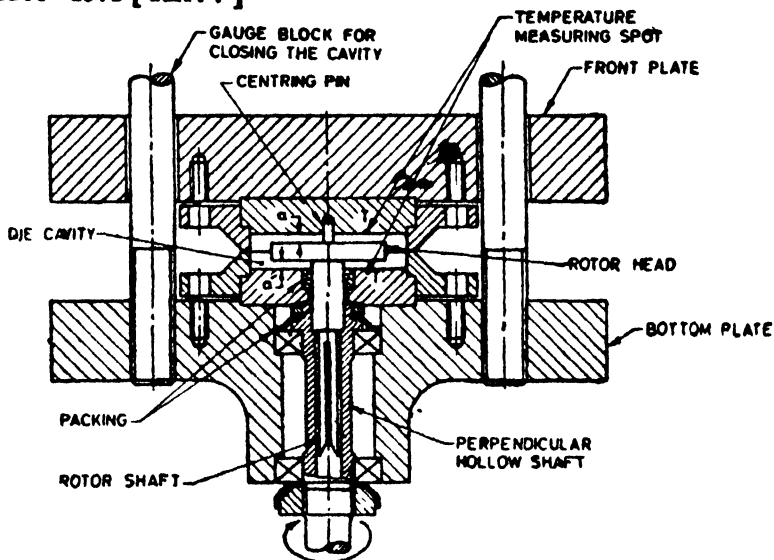

FIG. 1 ESSENTIAL PARTS OF THE SHEARING DISK VISCOMETER

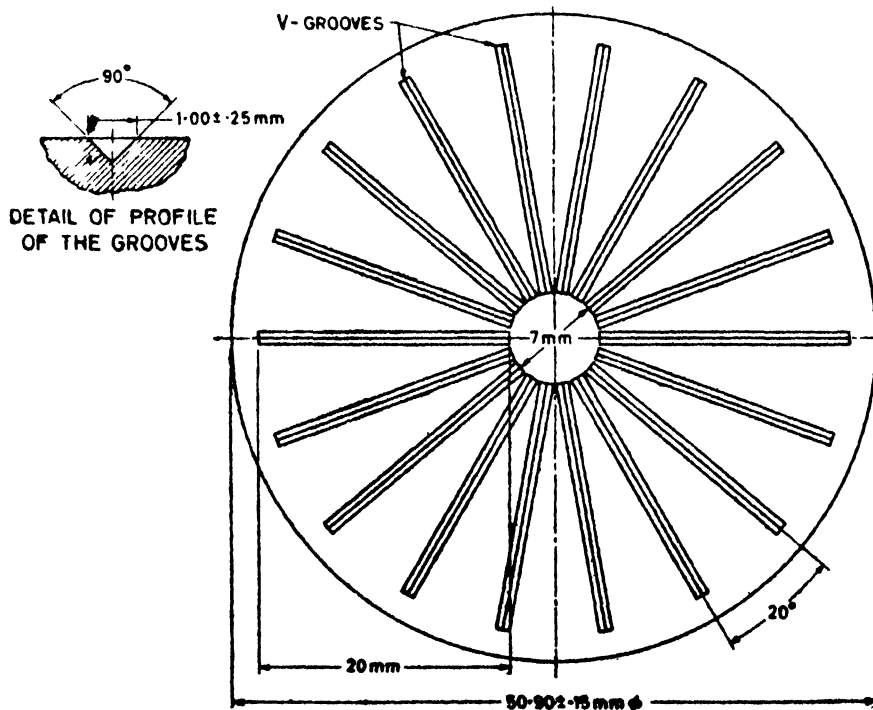

FIG. 2 RADIAL V-GROOVES OF DIE CAVITY

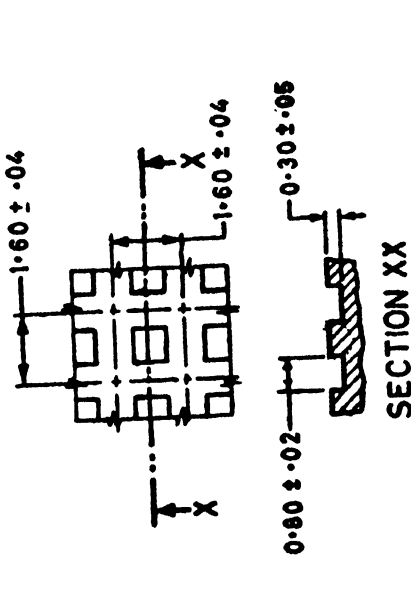

FIG. 3A WALL PROFILE OF THE DIE CAVITY

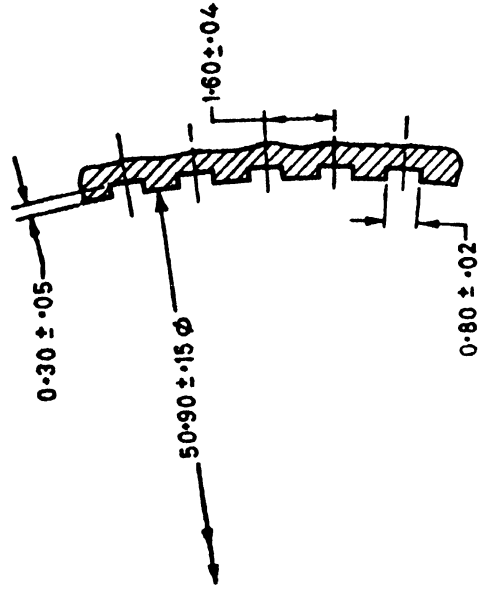
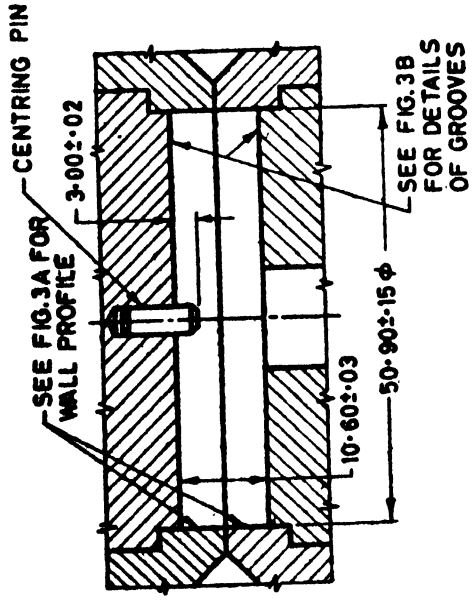

FIG. 3B RECTANGULAR SECTION GROOVES



All dimensions in millimetres.

FIG. 3 DIE CAVITY

3.1.3 The rotor (see Fig. 4) surfaces are grooved as described for the die cavity formed from four pieces of steel. The hardened rotor is fastened to a shaft not exceeding 11 mm in diameter and positioned securely so that in the closed die cavity the clearance above the rotor (see *a* in Fig. 1) does not differ from the clearance below the rotor (see *a* in Fig. 1) by more than 0.25 mm. The eccentricity or runout of the rotor while turning in the viscometer should not exceed 0.013 mm. The rotor shaft bears on the spindle which turns the rotor and not on the wall of the die cavity. The clearance at the point where the rotor enters the cavity should be small enough to prevent rubber leaving the cavity. A grommet may be used as a seal at this point.

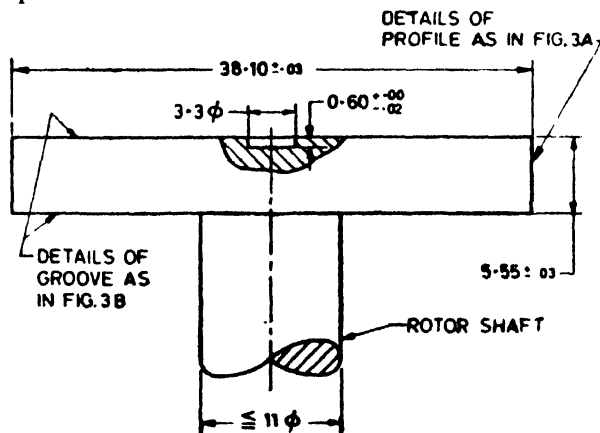

All dimensions in millimetres.

FIG. 4 ROTOR

3.1.4 The dies forming the die cavity are mounted on, or form part of platens equipped with a heating device capable of maintaining the die cavity within 0.5°C of the test temperature.

NOTE — The test temperature is defined as the steady state temperature of the closed cavity, with rotor in place but without rubber. Since a temperature differential exists between the platens and the die cavity, it is necessary to adjust the platen temperatures to obtain the correct cavity temperature. In making such adjustments it is important that the temperature of the two platens be within 0.3°C of each other. The cavity temperature may be measured with calibrated thermocouples or thermistors using lead wires about 0.3 mm in diameter to minimize thermal conduction to the exterior.

3.1.5 The die cavity may be closed by hydraulic, pneumatic or mechanical means. If fluid pressure is used, a force of 1 400 kg may be required for initial closure when rubbers of very high viscosity are tested. At least 10 seconds before starting the viscometer, the force is reduced to 340 ± 20 kgf and maintained at this value during the test. If mechanical closure is used, the platens are adjusted, preferably by means of a gauge

block so that the total deformation of the parts is between 0.10 mm and 0.15 mm when the die cavity is closed at the test temperature. For all types of closing device, the closure is adjusted so that a piece of thin soft tissue paper not thicker than 0.04 mm, placed between the meeting surfaces shows a continuous pattern of uniform intensity when the die cavity is closed.

3.1.6 The torque required to turn the rotor is recorded or indicated on a linear scale graduated in Mooney viscosity units so that a torque of 84.6 ± 0.2 cm.kg on the rotor equals 100 on the scale. The scale is capable of being read easily to 0.5 units and is calibrated by means of weights fastened to a special rotor with flexible wire not over 0.5 mm in diameter passing over pulleys free of friction. During the calibration the rotor is turned at 2 rev/min and the platens are at the test temperature. The reading should be zero with the torque removed and 100 ± 0.5 when a torque of 84.6 cm.kg is applied.

3.1.7 After calibration, the scale reading is adjusted to zero with the test rotor turning in the empty, closed die cavity at 2 rev/min. The fluctuations in readings during a period of half a minute or more should be less than 0.5 unit.

4. PROCEDURE

4.1 Preparation of Rubber Test Piece — Prepare two disks of rubber each about 45 to 50 mm in diameter and 6 to 8 mm in thickness to fill completely the cavity of the viscometer, in accordance with 3.1.1 (see Page 4). The rubber disks should be as free as possible from air and from pockets that may trap air against the rotor and die surfaces. A hole is pierced or cut through the centre of one disk to permit the insertion of the rotor stem.

4.2 Heat the die cavity and rotor to the test temperature of 100°C and allow to reach a steady state. Open the die cavity, insert the rotor stem through the hole in test disk, place the rotor in a viscometer, place the solid test disk centrally on the rotor and close the die cavity as quickly as possible. Insert, if necessary, a film of transparent cellulosic material approximately 0.03 mm in thickness between the rubber and metal surfaces to facilitate removal after test when testing low-viscosity or sticky materials. Note the time of closing the die cavity and allow the rubber to heat for one minute. Turn the rotor at 2.00 ± 0.02 rev/min, unless otherwise specified; after the specified time of preheat. If the viscosity is not recorded continuously, observe the indicator and scale continuously during the 30 seconds interval preceding the specified time of reading and the minimum value to the nearest 0.5 unit during this interval as the viscosity. For reference purposes, take readings at 5 seconds interval from 1 minute before to 1 minute after a 4-minute test period. Draw smooth curve

through the minimum points of the periodic fluctuations or through all points if there are no fluctuations. Take the viscosity as the point where the curve intersects the time specified. If a recorder is used, take the viscosity from the recorded curve in the same manner as specified for the plotted curve.

NOTE — The temperature gradients and rate of heat transfer vary among viscometers, particularly if different types of heating are employed. Therefore, the values obtained with different viscometers may be expected to be more comparable after the rubber has attained the test temperature. Usually this condition is reached about 10 minutes after the die cavity is closed. For most rubbers, the reading is not altered appreciably by permitting the rubber to heat in the viscometer for different times, provided the viscosity is read at a specified time. The running time should never be less than 2 minutes.

5. REPORT

5.1 The report shall include the following:

- a) Mooney viscosity number (M);
- b) Temperature of test;
- c) Rotor size, large or small (L or S);
- d) Time interval of preheat; and
- e) Time of reading after preheat.

NOTE — Results of a typical test shall be reported as follows:

50 ML 4 (100°C)

where

M = Mooney units,

L = large rotor,

4 = test period in minutes, and

100°C = test temperature.

6. REPRODUCIBILITY OF RESULTS

6.1 Note on Reproducibility of Results — The standard deviation for measurement on the same instrument of a uniform sample of rubber is about 0.2 unit. Variation in sample preparation results in standard deviations of about 1 unit; recorded figures from laboratories working with synthetic rubber production range from 0.20 to 0.75 units. The standard deviation is substantially independent of the viscosity, at least within the range of 40 to 90 units. Variability among laboratories may cause even larger variations in results. Parts of the interlaboratory variability is due to sample preparation and part to errors in calibrating or adjusting the viscometer.

COMPOUNDING OF RECLAIMED RUBBER FOR TESTING OF PHYSICAL PROPERTIES

(RR : 8)

1. SCOPE

1.1 This method describes a standard procedure for compounding reclaimed rubber for evaluating its physical properties, such as tensile stress-strain properties.

2. TERMINOLOGY

2.1 **Friction Ratio** — Ratio of the speed of the fast to the slow roll of a rubber mixing mill.

3. APPARATUS

3.1 **Mixing Mill** — The laboratory mixing mill has two parallel and cylindrical hardened steel rolls 15.25 ± 0.25 cm in outside diameter. The rolls are fitted with adjustable guides to allow a maximum working width and of 26.5 ± 1.5 cm. The mill has a provision for good water circulation so that the roll surfaces are maintained at ambient temperature during mixing. The two rolls rotate at different speeds. The speed of the slow roll is 24 ± 2 rev/min and the friction ratio is 1 : 1.4.

4. PROCEDURE

4.1 **Test Recipe** — Using a test portion of the homogenized reclaimed rubber prepared as given in 3.1.1 (see Page 4), make a mix of the following composition:

	<i>Parts by Mass</i>
Reclaimed rubber	<i>M</i> *
Stearic acid (conforming to Grade 3 of IS : 1675-1960†)	2.0
Zinc oxide (conforming to IS : 3399-1965‡)	5.0
Mercaptobenzthiazole (rubber grade)	0.5
Diphenyl guanldine (rubber grade)	0.2
Sulphur (rubber grade)	3.0

*The mass of rubber sufficient to give 100 parts of rubber hydrocarbon in the mix. For example, if rubber hydrocarbon content is 50 percent, then $M = 200$ g of reclaimed rubber.

†Specification for stearic acid, technical.

‡Specification for zinc oxide for rubber industry.

4.2 Method of Compounding — Weigh accurately 500 g of reclaim (relative density 1.5). Weigh accurately activators and curatives according to the test recipe given above in proportion to the amount of reclaim used. Set the rolls of the mill to give a small freely rolling bank of the reclaim not greater than 12.5 mm in diameter. The mill rolls shall be cool and at ambient temperature. As soon as the reclaim bands on the mill and forms a smooth sheet, add activators and curatives, spreading across the full width of the roll gradually for good dispersion. Cut batch from side to side alternately approximately six times each direction. Roll batch and insert endwise six times. Sheet out the batch to a thickness of about 6 mm and cool the sheet. Condition the compound for 2 to 24 hours at ambient temperature. After conditioning pass the compound through the rolls of the mixing mill at ambient temperature, rolling endwise three times, and sheet out to a thickness of about 2.5 mm. Mould the slab at 141°C for 10, 15, 20 and 30 minutes.

NOTE 1 — For other reclaims of different relative densities a suitable adjustment in the amount of reclaim is necessary to maintain the same volume.

NOTE 2 — If the batch sticks to the rear roll a scraper blade may be used instead of cutting knife.

4.3 Testing — Determine the tensile stress-strain properties in accordance with IS : 3400 (Part I)-1965*.

*Methods of test for vulcanized rubbers: Part I Tensile stress-strain properties.

BUREAU OF INDIAN STANDARDS

Headquarters:

Manak Bhavan, 9 Bahadur Shah Zafar Marg, NEW DELHI 110002

Telephones 23230131, 23233375, 23239402 Fax 91+011 23239399, 23239382

E - Mail bis@vsnl.com

website <http://www.bis.org.in>

Central Laboratory:

Plot No 20/9, Site IV, Sahibabad Industrial Area, SAHIBABAD 201010

Telephone

27700 32

Regional Offices:

Central Manak Bhavan, 9 Bahadur Shah Zafar Marg, NEW DELHI 110002 2323 76 17

*Eastern 1/14 CIT Scheme VII M, V I P Road Kankurgachi KOLKATA 700054 2337 86 62

Northern SCO 335-336, Sector 34-A, CHANDIGARH 160022 260 38 43

Southern C I T Campus, IV Cross Road CHENNAI 600113 2254 19 84

Western Manakalaya, E9, MIDC, Behind Marol Telephone Exchange,
Andheri (East), MUMBAI 400093 2832 92 95

Branch Offices:

Pushpak, Nurmohamed Shaikh Marg, Khanpur, AHMEDABAD 380001 560 13 48

Peenya Industrial Area, 1st Stage, Bangalore-Tumkur Road, BANGALORE 839 49 55

Commercial-cum-Office Complex, Opp Dushera Maidan, E-5 Arera Colony,
Bittan Market, BHOPAL 462016 242 34 52

62-63, Ganga Nagar, Unit VI, BHUBANESHWAR 751001 240 31 39

5th Floor, Koval Towers, 44 Bala Sundaram Road, COIMBATORE 641018 221 01 41

SCO 21, Sector 12, Faridabad 121007 229 2175

Savitri Complex, 116 G T Road, GHAZIABAD 201001 286 1498

Plot No A-20-21, Institutional Area, Sector 62, Goutam Budh Nagar, NOIDA-201307 240 22 06

53/5 Ward No 29, R G Barua Road, 5th By-lane, Apurba Sinha Path,
GUWAHATI 781003 254 11 37

5-8-56C, L N Gupta Marg, Nampally Station Road, HYDERABAD 500001 2320 10 84

E-52, Chitaranjan Marg, C-Scheme, JAIPUR 302001 237 38 79

117/418 B, Sarvodaya Nagar, KANPUR 208005 221 82 92

Sethi Bhawan, 2nd Floor, Behind Leela Cinema, Naval Kishore Road,
LUCKNOW 226001 221 56 98

NIT Building, Second Floor, Gokulpat Market, NAGPUR 440010 252 51 71

Mahabir Bhavan, 1st Floor, Ropar Road, NALAGARH 174101 22 14 51

Patliputra Industrial Estate, PATNA 800013 226 28 08

First Floor, Plot Nos 657-660, Market Yard, Gultkdi, PUNE 411037 426 86 59

"Sahajanand House" 3rd Floor, Bhaktinagar Circle, 80 Feet Road,
RAJKOT 360002 237 82 51

T C No 14/1421, University P O Palayam, THIRUVANANTHAPURAM 695034 232 21 04

1st Floor, Udyog Bhavan, VUDA, Siripuram Junction, VISHAKHAPATNAM-03 271 28 33

Sales Office is at 5 Chowringhee Approach, P O Princep Street, KOLKATA 700072 22 12 6215

Sales Office is at Novelty Chambers, Grant Road, MUMBAI 400007 2309 65 28